

CCTV Camera
WV-BP312

Operating Instructions



Panasonic®

Before attempting to connect or operate this product,
please read these instructions completely.

CAUTION:

Before attempting to connect or operate this product, please read the label on the bottom.

CONTENTS

PREFACE	2
FEATURES	2
PRECAUTIONS	3
MAJOR OPERATING CONTROLS AND THEIR FUNCTIONS	4
CONNECTION	7
LENSES	10
FOCUS OR FLANGE-BACK ADJUSTMENT	17
INSTALLATION OF CAMERA	18
PREVENTION OF BLOOMING AND SMEAR	19
LENS MAINTENANCE AND CLEANING	19
SPECIFICATIONS	20
STANDARD ACCESSORIES	21
OPTIONAL ACCESSORIES	21

PREFACE

Panasonic's WV-BP312 CCTV camera introduce a new level of high picture quality through the use of a 1/3 inch interline transfer CCD having 771 horizontal pixels (picture elements). High performance-to-cost ratio is achieved through the use of newly developed Sync IC's and ability to shoot indoor scenes with a fixed iris lens by use of Electronic Light Control (ELC) function.

FEATURES

- Minimum illumination of 0.008 footcandle (0.08 lux) at F1.4 and signal-to-noise ratio of 46 dB by employing a 1/3 inch interline transfer CCD image sensor with 771 (H) x 492 (V) pixels.
- 570 lines of horizontal resolution
- Either optional standard C-mount or Special C-mount (CS-mount) auto iris control lens can be used with.
- Selectable auto iris control signal for the lens either a video signal or DC control signal.
- Various Sync functions, including Gen-lock.
- Ability to shoot indoor scene with a fixed iris lens by use of the Electronic Light Control (ELC) function.

PRECAUTIONS

1. Do not attempt to disassemble the camera.

To prevent electric shock, do not remove screws or cover.

There are no user-serviceable parts inside.

Refer servicing to qualified service personnel.

2. Handle the camera with care.

Do not abuse the camera. Avoid striking or shaking it.

The camera could be damaged by improper handling or storage.

3. Do not expose the camera to rain or moisture, or try to not operate it in wet areas.

Do take immediate action if ever the camera does become wet. Turn the power off and refer servicing to qualified service personnel. Moisture can damage the camera and can also create the danger of electric shock.

4. Never face the camera towards the sun.

Whether the camera is in use or not, never face it towards the sun. Do use caution when operating the camera in the vicinity of spot lights or other bright lights and light reflecting objects.

5. Do not operate the camera beyond its temperature, humidity or power source ratings.

Do not use the camera in an extreme environment where high temperature or high humidity exist. Use the camera under conditions where the temperature is within -22°F - 122°F (-30°C - $+50^{\circ}\text{C}$), and the humidity is below 90%. The input power source is 12V DC.

Caution:

To prevent fire or shock hazard, the UL listed wire VW-1, style 1007 should be used for 12V DC Input Terminals.

MAJOR OPERATING CONTROLS AND THEIR FUNCTIONS

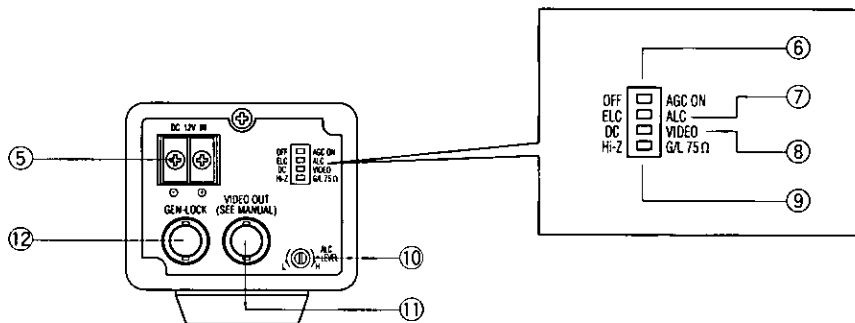
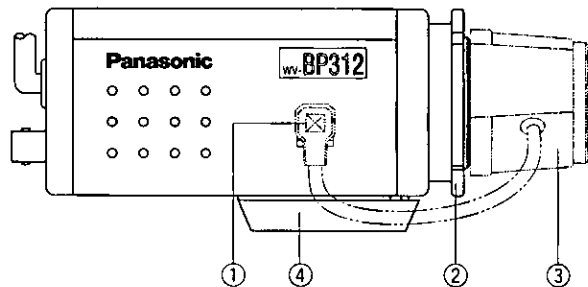

(1) Auto Iris Lens Connector

This 4-pin female connector supplies the power and either video signal or DC control signal to the auto iris lens.

A 4-pin male connector, which can be mated with the camera's female connector, is supplied as a standard accessory (Part No. YFE4191J100).

This male connector can be installed on lenses which have incompatible type connector.

See page 16 for installation details

(2) Flange-back Adjusting Ring

This ring is used to adjust the back focal length or picture focus by rotating this ring to clockwise for C-mount lens or counterclockwise for special C-mount (CS-mount) lens.

(3) Lens (Option)

See pages 10, 11, 12, 13 and 14 for details on lens selection.

(4) Camera Mounting Screw Hole

This threaded hole (1/4"-20) is used to mount the camera onto a mounting bracket or tripod.

(5) DC 12V In Terminal (DC 12V IN)

This terminal accepts 12V DC power source (10.5V - 16V)

Cautions:

1. Connect this to a 12V DC class 2 power supply only.
2. To prevent fire or shock hazard, the UL listed wire VW-1, style 1007 should be used for the cable for DC 12V Input Terminal.

(6) AGC On/Off Switch (AGC ON/OFF)

This switch is used to select the gain of the video amplifier as follows;

ON: When the lens iris is fully opened under a low light condition, a clear picture is obtained by automatic increase of the gain.

OFF: A natural and low-noise picture is obtained under a low light condition.

(7) Electronic Light Control / Automatic Light Control Selection Switch (ELC/ALC)

This switch is used to select the lens as follows.

ALC: Choose this position when using an auto iris lens.

ELC: Choose this position when using a fixed or manual iris lens.

(8) Lens Selection Switch (VIDEO/DC)

This switch is used to select the supplied auto iris control signal to the lens from the Auto Iris Lens Connector (1).

DC: Choose this position when the auto iris control lens requiring DC control signal is mounted on the camera. See pages 10, 11, 12 and 13 for a list of these lenses.

VIDEO: Choose this position when the auto iris control lens requiring video signal such as WV-LA8B, WV-LA16B, WV-LA25B, WV-LA50B, is mounted on the camera.

(9) Gen-lock Termination Switch (G/L 75Ω / Hi-Z)

When looping through the Gen-lock video input signal, set this switch to the Hi-Z position and in all other cases, set this switch to the 75-ohm position.

(10) Auto Iris Level Control (ALC LEVEL, L (Low)/ H (High))

This control adjusts the control level of the auto iris control when the Lens Selection Switch (8) is set to the DC position and the auto iris lens which requires the DC control voltage such as WV-LA12 etc., is mounted on the camera.

Note: When the Lens Selection Switch (8) is set to the VIDEO position, the auto iris level control should be adjusted by the lens.

(11) Video Output Connector (VIDEO OUT)

This connector is used to connect a coaxial cable to the VIDEO INPUT of the specified monitor. This connector may be connected to the CAMERA INPUT of the camera drive unit. The camera drive unit supplies DC power and vertical drive pulses, and video output from the camera.

(12) Gen-lock Video Input Connector (GEN-LOCK)

A composite B/W or color 1.0 Vp-p/75 ohms video signal, or black burst 0.3 Vp-p/75 ohms or composite sync 4 Vp-p/75 ohms should be supplied to this connector for external synchronization.

CONNECTION

1. A 12V DC power supply is required.
2. Connect the power cable to the DC 12V In Terminal (5) on the rear panel of the camera.

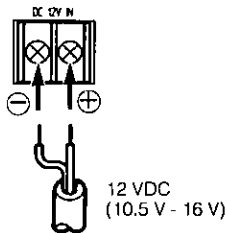

Resistance of copper wire [at 68°F (20°C)]

Copper wire size (AWG)	#24 (0.22mm ²)	#22 (0.33mm ²)	#20 (0.52mm ²)	#18 (0.83mm ²)
Resistance ohms/ft	0.257	0.165	0.099	0.059
Resistance ohms/m	0.078	0.050	0.030	0.018

- Calculation method of maximum cable length between camera and power supply.

$$10.5V DC \leq V_A - (R \times 0.42 \times L) \leq 16V DC$$

L : Cable length (meter)

R : Resistance of copper wire (ohms/meter)

V_A : DC output voltage of power supply unit

$$L \text{ standard} = \frac{V_A - 12}{0.42 \times R} \text{ (meter)}$$

$$L \text{ minimum} = \frac{V_A - 16}{0.42 \times R} \text{ (meter)}$$

$$L \text{ maximum} = \frac{V_A - 10.5}{0.42 \times R} \text{ (meter)}$$

Caution:

To prevent fire or shock hazard, the UL listed wire VW-1, style 1007 should be used for the cable for DC 12V Input Terminal.

Video Cable

1. It is recommended to use a video monitor whose resolution is at least equal to the camera's.
2. Terminate the camera output with 75-ohm resistor at the furthest end of its cable run.
 - It is recommended to use 75-ohm coaxial cable.
 - Always set the last monitor's termination switch to 75 ohms, and set the termination switches of intermediate monitors to HIGH (Hi-Z) position.

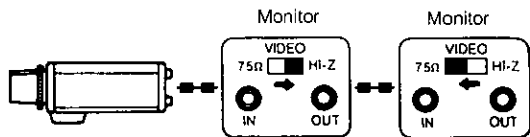

- The maximum extensible coaxial cable length between the camera and the monitor is shown in the table 1. Since cable quality varies among manufactures, please verify video quality before final installation, if maximum lengths are to be used.

Table 1

Type of coaxial cable		RG-59/U (3C-2V)	RG-6U (5C-2V)	RG-11/U (7C-2V)	RG-15/U (10C-2V)
Recommended maximum cable length	(ft)	825	1,650	1,980	2,640
	(m)	250	500	600	800

3. Wiring precautions:

- Do not bend coaxial cable into a curve whose radius is smaller than 10 times the cables diameter.
 - Never staple the cable-not even with circular staples. Impedance mismatching will occur.
 - Never crush or pinch the cable.
- All of these will change the impedance of the cable and cause poor picture quality.

Gen-Lock Video Cable

Connect the coaxial cable for gen-lock video signal between the Gen-lock Video Input Connector (12) and the reference composite video output (B/W or color 1.0 Vp-p/75 ohms) or composite sync (4 Vp-p/75 ohms) or black burst (0.3 Vp-p/75 ohms) of the production system.

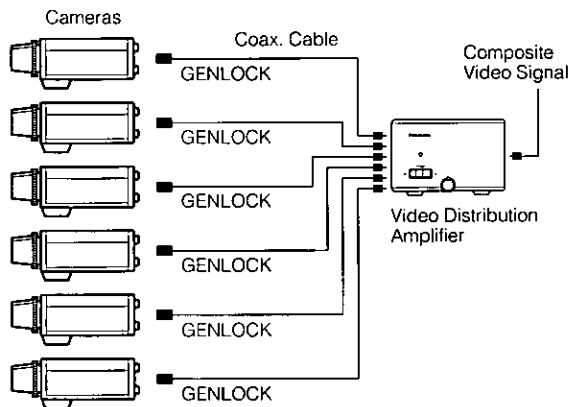

- * The Gen-lock termination Switch of all cameras should be set to 75 ohm position.

• Gen-Lock (Looping through)

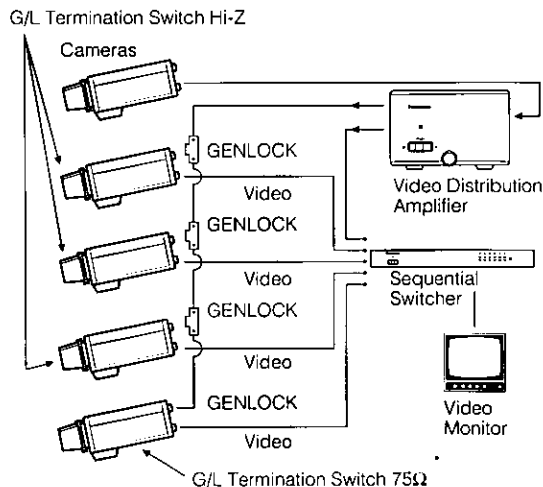

- * The Gen-lock Termination Switch of the furthest camera should be set to 75 ohm position and that of all other cameras should be set to Hi-Z position.
Note: The gen-lock input signal should meet with EIA standard and should not contain jitter such as VTR playback signal.

LENSES

1. Selection of Lens

<Auto Iris Lenses>

Models Specifications	WV-LA2.8 (Wide Angle)	WV-LA6B2 (Wide Angle)	WV-LA12B2 (Standard)	WV-LA18 (Telephoto)	WV-LA36 (Telephoto)	
Image Size	1/2" (6.4 (H) x 4.8 (V) mm)					
Focal Length	2.8 mm	6 mm	12 mm	18 mm	36 mm	
Maximum Aperture Ratio	1 : 1.4	1 : 1.4	1 : 1.4	1 : 1.4	1 : 1.8	
Angular Field of View 1/3"	H	87.5°	43.5°	22.8°	15.5°	7.7°
	V	69.2°	33.0°	17.1°	11.5°	5.7°
Focusing Range	Adjusted by Camera			0.89 ft - ∞ (0.27 m - ∞)	3.3 ft - ∞ (1 m - ∞)	
Mount	CS-mount, 1"-32UN					
Filter Size	None	None	None	M37.5 mm P = 0.5	M37.5 mm P = 0.5	
Dimensions	ø1-11/16" x 1-1/4" (ø43 x 32 mm)	ø1-11/16" x 1-3/8" (ø43 x 35.3 mm)	ø1-11/16" x 1-3/8" (ø43 x 35.3 mm)	ø1-11/16" x 1-5/8" (ø43 x 41 mm)	ø1-11/16" x 1-5/8" (ø43 x 41 mm)	
Weights	0.09 lbs. (40g)	0.11 lbs. (50g)	0.09 lbs. (40g)	0.15 lbs. (70g)	0.18 lbs. (80g)	

- Dimensions and weights indicated are approximate.
- Specifications are subject to change without notice.

<Auto Iris Lenses>

Models Specifications	WV-LZ81/6A (Motorized Zoom)	WV-LZ81/10 (Motorized Zoom)	WV-LA4R5C3A (Wide Angle)	WV-LA9C3A (Standard)	WV-LZ61/10 (Motorized Zoom)	
Image Size	1/2" (6.4 (H) x 4.8 (V) mm)		1/3" (4.8 (H) x 3.6 (V) mm)			
Focal Length	8.5 - 51 mm (6X)	8 - 80 mm (10X)	4.5 mm	9 mm	6 - 60 mm (10X)	
Maximum Aperture Ratio	1 : 1.2 (Wide) 1 : 1.3 (Tele)	1 : 1.4 (Wide) 1 : 1.7 (Tele)	1 : 1.2	1 : 1.2	1 : 1.6 (Wide) 1 : 2.6 (Tele)	
Angular Field of View 1/3"	H	Wide : 31.4° Tele : 5.5°	Wide : 33.5° Tele : 3.5°	56.4°	29.6°	Wide : 43.7° Tele : 4.6°
	V	Wide : 23.5° Tele : 4.1°	Wide : 25.2° Tele : 2.6°	43.3°	22.2°	Wide : 33.0° Tele : 3.5°
Focusing Range	3.3 ft - ∞ (1m - ∞)	3.6 ft - ∞ (1.1m - ∞)	Adjusted by Camera		4.0 ft - ∞ (1.2m - ∞)	
Mount	CS-mount, 1"-32UN					
Filter Size	M49 mm, P = 0.75	M55 mm, P = 0.75	None		M35.5 mm, P = 0.5	
Dimensions	3-3/8"(W) x 2-7/16"(H) x 4"(D) [86(W) x 62(H) 102(D) mm]	3-3/16"(W) x 2-5/8"(H) x 4-5/8"(D) [81(W) x 66(H) 117.5(D) mm]	ø1-11/16" x 1-1/2" (ø43 x 38.5 mm)	ø1-11/16" x 1-1/2" (ø43 x 38.5 mm)	2-13/16"(W) x 2-1/16" (H) x 2-3/4"(D) [71(W) x 52(H) 70.5(D) mm]	
Weights	0.93 lbs. (420g)	0.97 lbs. (440g)	0.09 lbs. (42g)	0.09 lbs. (40g)	0.46 lbs. (210g)	

- Dimensions and weights indicated are approximate.
- Specifications are subject to change without notice.

<Auto Iris Lenses>

Models		WV-LA4510 (Wide Angle)	WV-LA608 (Wide Angle)	WV-LA1208 (Standard)	WV-LZ83/6 (Motorized Zoom)
Specifications					
Image Size		1/2" (6.4 (H) x 4.8 (V) mm)			
Focal Length		4.5 mm	6 mm	12 mm	8.5 - 51 mm (6X)
Maximum Aperture Ratio		1 : 1.0	1 : 0.75	1 : 0.8	1 : 0.8 (Wide) 1 : 1.0 (Tele)
Angular Field of View 1/3"	H	56.9°	43.8°	23.8°	Wide : 31.3° Tele : 5.5°
	V	43.6°	33.1°	17.6°	Wide : 23.4° Tele : 4.1°
Focusing Range		Adjusted by Camera			4.0 ft - ∞ (1.2m - ∞)
Mount		CS-mount, 1"-32UN			
Filter Size		None	M46 mm, P = 0.75	M46 mm, P = 0.75	M67 mm, P = 0.75
Dimensions		2-1/8"(W) x 1-11/16"(H) x 1-1/16"(D) [54.5(W) x 43(H) x 43 (D) mm]	2-1/2"(W) 2-1/16"(H) x 2-3/16"(D) [64(W) x 52(H) x 55 (D) mm]	2-7/8"(W) x 2-5/8"(H) x 2-7/8"(D) [73(W) x 66(H) x 72.5(D) mm]	3-1/2"(W) x 3"(H) x 4-13/16"(D) [90(W) x 77(H) 123(D) mm]
Weights		0.19 lbs. (85g)	0.34 lbs. (155g)	0.56 lbs. (255g)	1.63 lbs. (740g)

- **When using the above lenses with the camera, be sure to read instruction manual of lenses.**
- Dimensions and weights indicated are approximate.
- Specifications are subject to change without notice.

<Auto Iris Lenses>

Models		WV-LA210C3 (Wide angle)	WV-LA408C3 (Wide angle)	WV-LA908C3 (Standard)
Specifications				
Image Size		1/3" (4.8(H) x 3.6(V) mm)		
Focal Length		2.1 mm	4.5 mm	9 mm
Maximum Aperture Ratio		1 : 1.0	1 : 0.75	1 : 0.75
Angular Field of View 1/3"	H	107.6°	57.2°	31.3°
	V	88.0°	43.7°	23.5°
Focusing Range		Adjusted by Camera		
Mount		CS-mount, 1"-32UN		
Filter Size		None	M40.5 mm, P=0.5	M40.5 mm, P=0.5
Dimensions		2-7/16"(W) x 2-1/16"(H) x 1-5/8"(D) [62.5(W) x 52(H) x 41(D) mm]	2-7/16"(W) x 2-1/16"(H) x 2-1/4"(D) [62.5(W) x 52(H) x 57.5(D) mm]	2-7/16"(W) x 2-1/16"(H) x 2-1/4"(D) [62.5(W) x 52(H) x 57.5(D) mm]
Weight		0.24 lbs. (110g)	0.31 lbs. (140g)	0.30 lbs. (135g)

- **When using the above lenses with the camera, be sure to read instruction manual of lenses.**
- Dimensions and weights indicated are approximate.
- Specifications are subject to change without notice.

<Manual and Fixed Iris Lenses>

Specifications		Models			
		WV-LF6 (Wide Angle)	WV-LF12 (Standard)	WV-LF4R5C3A (Wide Angle)	WV-LF9C3A (Standard)
Image Size		1/2" (6.4 (H) x 4.8 (V) mm)		1/3" (4.8 (H) x 3.6 (V) mm)	
Focal Length		6 mm	12 mm	4.5 mm	9 mm
Maximum Aperture Ratio		1 : 1.4	1 : 1.4	1 : 1.2	1 : 1.2
Angular Field of View 1/3"	H	43.5°	22.2°	56.4°	29.6°
	V	32.9°	16.7°	43.3°	22.2°
Iris		Fixed	Fixed	Fixed	Fixed
Focusing Range		Adjusted by Camera			
Mount		CS-mount, 1"-32UN			
Filter Size		M34 mm, P = 0.5	M34 mm, P = 0.5	M30.5 mm, P = 0.5	M30.5 mm, P = 0.5
Dimensions		ø1-1/2" x 1-5/8" (ø38 x 41 mm)	ø1-1/2" x 1-5/8" (ø38 x 41 mm)	ø1-3/8" x 1-7/16" (ø34.4 x 36 mm)	ø1-3/8" x 1-7/16" (ø34.4 x 36 mm)
Weights		0.08 lbs. (39g)	0.07 lbs. (33g)	0.06 lbs. (29g)	0.05 lbs. (23g)

- Dimensions and weights indicated are approximate.
- Specifications are subject to change without notice.

2. Installation of Auto Iris Lens Connector

When you use an auto iris lens other than listed on pages 10, 11, 12 and 13, for example a video servo ALC lens, install the lens connector (YFE4191J100) coming with the camera as follows.

The following installation should be made by qualified service personnel or system installers.

- (1) Cut off the iris control cable at the edge of lens connector and then cut off the outer cable cover as shown in the diagram.

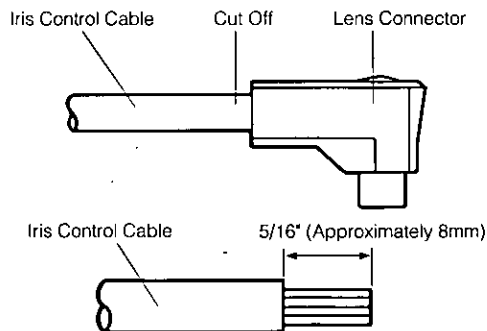

- (2) Cut off the inner cable covers of the iris control cable as shown in the diagram.

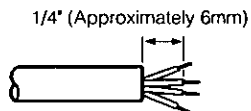

- (3) Put the heat shrinkable tubes or equivalent tubes on the inner cables of the iris control cable.
- (4) Solder the inner cables of the iris control cable at the pin-plug block according to the following pin assignment and cover the heat shrinkable tubes or equivalent tubes over the soldered area and heat on the tubes to shrink them.
Pin 1: Power source; +9V DC, 50mA Max.
Pin 2: Not used
Pin 3: Video signal; 1.3 Vp-p/40 kohms
Pin 4: Shield, ground
(Set the Lens Selection Switch (8) to the VIDEO position)

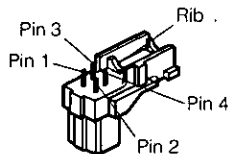

- (5) Both the connector cover and connector should be positioned to interlock.

Note:

Cut off the rib on the connector, when the iris control cable is too thick and the connector cover and connector can not be interlocked.

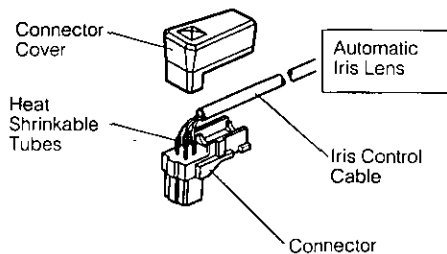

3. Mounting the Lens

When you use the lens other than listed on pages 10, 11, 12, 13 and 14, lens mount should be C-mount or special C-mount (CS-mount 1"-32UN) and lens weight should be less than 0.99 lbs. (450g). If not, both the lens and camera should be secured.

The protrusion of the rear of the lens should be as shown below.

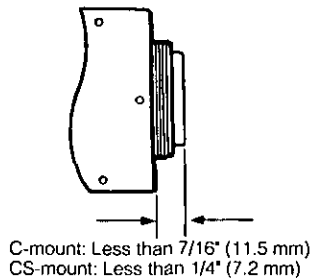

Caution:

Always set the Flange-back adjusting ring to fully clockwise (C-mount side) by loosening one screw on the ring before mounting the lens, otherwise the inner glass and CCD image sensor could be damaged by the lens.

- (1) Mount the lens by turning it clockwise onto the lens mount of the camera.
- (2) Connect the lens cable to the Auto Iris Lens Connector on the camera when an auto iris lens is used.

- (3) Set the Lens Selection Switch (8) to the proper position as follows.

DC: The mounted lens is one of the lenses listed on pages 10, 11, 12 and 13 or one that requires the DC control signal for auto iris control.

VIDEO: The mounted lens requires video signal for auto iris control.

NOTE:

Refer to item-8 on page 6 for the lens selection switch.

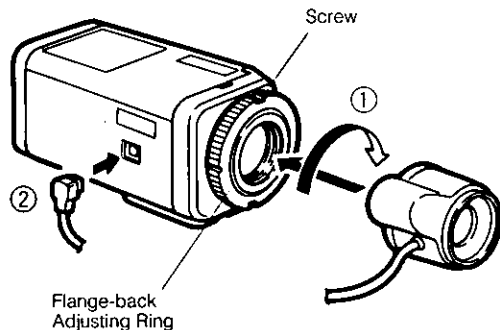

FOCUS OR FLANGE-BACK ADJUSTMENT

The following adjustment should be made by qualified service personnel or system installers.

1. Loosen screws on the flange-back adjusting ring.

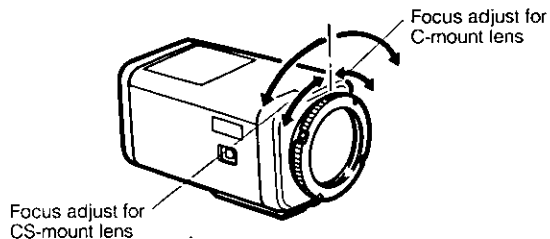

2. Turn the flange-back adjusting ring to the desired position.

Caution:

Do not turn this ring too much to counterclockwise as this could damage the inner glass and CCD image sensor.

3. Tighten the screws on the flange-back adjusting ring.

INSTALLATION OF CAMERA

- **Mounting from the bottom**

This camera is designed to be mounted from the bottom, as shown below. The mounting hole is a standard photographic pan-head screw size (1/4" - 20).

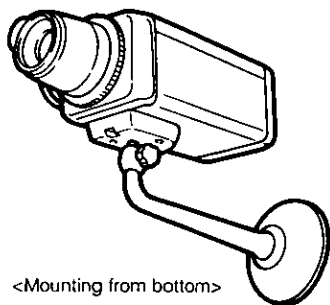

- **Mounting from the top**

Remove the mount adaptor from the bottom of the camera by removing the two fixing screws. Attach the mount adaptor to the top as shown in the diagram, then mount the camera on the mounting bracket.

Make sure that the two original fixing screws are used when mounting the mount adaptor as longer length screws may damage inner components.

Note: When installing the camera, use such a camera mounting bracket as to support the load of four times of the total weight.

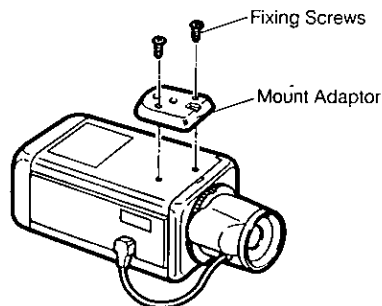
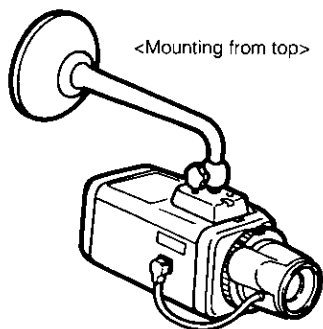

PREVENTION OF BLOOMING AND SMEAR

When the camera is aimed at a bright light, such as a spot light, or a surface that reflects bright light, smear or blooming may appear. Therefore, the camera should be operated carefully in the vicinity of extremely bright objects to avoid smear or blooming.

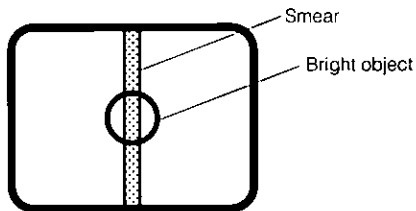

LENS MAINTENANCE AND CLEANING

1. Remove the lens connector.
2. Remove the lens, and inspect the camera CCD faceplate through the lens mount opening to assure that the faceplate is free of smudges or particles of dirt.
3. Clean the CCD faceplate, if necessary, using lens tissue or a cotton tipped applicator and ethanol.
4. Install the new lens.

SPECIFICATIONS

Pick-up Device:	771 (H) x 492 (V) pixels, Interline Transfer CCD
Scanning Area:	4.8 (H) x 3.6 (V) mm (Equivalent to scanning area of 1/3" pick-up tube)
Synchronization:	Internal, External or Multiplexed vertical drive (VD2) selectable
Scanning System:	2 : 1 interlace
Scanning:	525 lines / 60 fields / 30 frames
Horizontal:	15.734 KHz
Vertical:	59.94 Hz
Horizontal Resolution:	570 lines
Video Output:	1.0 Vp-p NTSC composite 75 ohms / BNC connector
Signal-to-Noise Ratio:	46 dB (AGC OFF)
Electronic Light Control:	Equivalent to continuous variable shutter speed between 1/60 sec. and 1/10,000 sec.
Minimum Illumination:	0.008 footcandle (0.08 lux) at F1.4, AGC ON
Gain Control:	Selectable AGC ON (+24 dB) or OFF
Lens Mount:	C-mount or Special C-mount (CS-mount) selectable
Ambient Operating Temperature:	-22°F - 122°F (-30°C - +50°C)
Ambient Operating Humidity:	Less than 90%
Power Source:	12V DC, VP Multiplex or 12V DC Selectable
Power consumption:	0.22A

Dimensions (without lens): 2-5/8" (W) x 2-3/16" (H) x 4-13/16" (D)
[67 (W) x 55 (H) x 123 (D) mm]
Weights (without lens): 1.0 lbs. (0.46kg)

Weights and dimensions indicated are approximate.
Specifications are subject to change without notice.

STANDARD ACCESSORIES

ALC Lens Connector (YFE4191J100) 1 pc.
Body Cap 1 pc.

OPTIONAL ACCESSORIES

Lenses : WV-LA2.8, WV-LA6B2, WV-LA12B2, WV-LA18, WV-LA36, WV-LA4510, WV-LA608, WV-LA1208,
WV-LA4R5C3A, WV-LA9C3A, WV-LA210C3, WV-LA408C3, WV-LA908C3, WV-LZ81/6A, WV-LZ81/10,
WV-LZ83/6, WV-LZ61/10, WV-LF6, WV-LF12, WV-LF4R5C3A, WV-LF9C3A

Panasonic

Broadcast & Television Systems Company

Division of Matsushita Electric Corporation of America

CLOSED CIRCUIT VIDEO EQUIPMENT DIVISION

Executive Office: One Panasonic Way, Secaucus, New Jersey 07094

Regional Offices:

Northeast: 43 Hartz Way, Secaucus, NJ 07094 (201) 348-7303

Southeast: 1854 Shackelford Court, Suite 115, Norcross, GA 30003 (404) 717-6835

Midwest: 1707 North Randall Road, Elgin, IL 60123 (708) 468-5200

Southwest: 4500 Amon Carter Blvd., Ft. Worth, TX 76155 (817) 685-1117

Western: 6550 Katella Ave., Cypress, CA 90630 (714) 373-7265

MATSUSHITA ELECTRIC OF CANADA LIMITED

5770 Ambler Drive, Mississauga, Ontario, L4W 2T3 Canada (905)624-5010

PANASONIC SALES COMPANY

DIVISION OF MATSUSHITA ELECTRIC OF PUERTO RICO, INC.

San Gabriel Industrial Park, 65th Infantry, Ave. KM. 9.5 Carolina, Puerto Rico 00630 (809)750-4300

N0794-0

YWV8QA3403AN

Printed in Japan

Ⓝ 13